

# HD/SD System Camera HXC-D70

**SONY**  
make.believe



**Exmor**  
FULL HD 3CMOS

# Opening a New World of HD Production

Sony introduces an ideal solution for HD/SD small studio operations with the HXC-D70 Full HD System Camera, HXCU-D70 Camera Control Unit (CCU), and DXF-C50WA 5-inch Color LCD Viewfinder.

The newly developed HXC-D70 is a high-performance camera which inherits field-proven operability from the highly regarded DXC-D Series of system cameras.

The HXC-D70 is equipped with the latest digital HD multi-core cable transmission technology, which allows the camera to be configured with the newly developed HXCU-D70 CCU.

Furthermore, the existing CCU-D50 CCU can also be used with the HXC-D70 for migration from SD to HD live production.



# Excellent Picture Quality

## Three Exmor full-HD CMOS sensors

The HXC-D70 is equipped with three 2/3-inch-type Exmor CMOS sensors, which deliver superior picture performance with full-HD resolution.

Due to Sony's advanced sensor technologies, this imager provides an brilliant sensitivity (F12 for 1920 x 1080/59.94i mode, F13 for 1920 x 1080/50i mode), a remarkable signal-to-noise ratio of 59 dB, and high horizontal resolution of 1,000 TV lines\*.

All of these excellent features result in high-quality digital signals with extremely low noise. This significantly enhances shooting in low-light environments.

In addition to the camera's high performance, a wide range of output formats are available including 1080i/50, 1080i/59.94, 720p/50, 720p/59.94, 576i/50, and 480i/59.94.

\* In 1920 x 1080i mode

# Variety of Picture Adjustment Functions

## Skin-tone detail

This function allows adjustment (emphasis or suppression) of the detail level for a specific hue or chroma area in the image, such as human skin tones.



Skin-tone detail control off

Skin-tone detail control on

Simulated images

## Selection of multiple gamma tables

Seven types of standard and four types of hyper gamma table are featured. The hyper gamma values enable cinema-like image creation with wide dynamic range

## Knee saturation

Hue and chroma in highlighted areas can be adjusted to reproduce natural human skin tones under strong lighting.



Knee Saturation OFF

Knee Saturation ON

Simulated images

# System Versatility

The HXC-D70 can be remotely controlled from the HXCU-D70 Camera Control Unit using a standard multi-core cable.

With Sony's newly developed signal transmission technologies, HD signals, electrical power, and communication signals can be transferred via a single multi-core cable.

Sony's BP-L Series battery can also be directly attached to allow stand-alone operation.

The HXC-D70 is ideal for a wide range of standard-definition (SD) and high-definition (HD) productions.

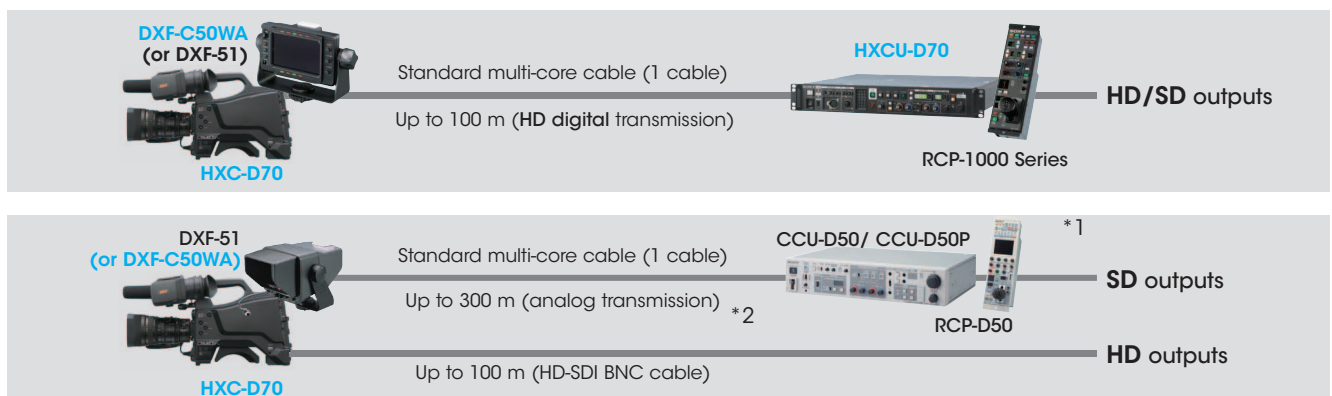

\*1 Some functions of the HXC-D70 cannot be controlled via the CCU-D50 and RCP-D50.

\*2 •75 m (246 feet) for component digital-SDI transmission via a CCZ-A cable (26-pin)

•200 m (656 feet) for component digital-SDI transmission using a separate low-loss coaxial video cable in addition to a CCZ-A cable

•Analog transmission for longer control distances of up to 300 m (984 feet) via a CCZ-A cable

# HXC-D70

## Two types of viewfinder interface

Interface for the DXF Series such as the DXF-51, DXF-C50WA, and 3.5-inch color LCD viewfinder (supplied with the HXC-D70K and HXC-D70L).

## Built-in optical ND filter with electrical CC filter

Optimum light and color control is easily achieved using an optical Neutral Density (ND) filter wheel and electronic Color Correction (CC). The use of electronic CC allows all filters in the filter wheel to be of the ND type, providing the operator with greater flexibility in depth-of-field and exposure control. Electronic CC can also be controlled using a remote controller, for even easier operation.

## Three accessory shoes

Various camera accessories can be attached.

**Front AF/MF Mode**

- Full AF • One-push AF • MF • AF/MF Assist

**Full MF Mode Back**

- Full MF (absolute focus position)

## Auto Focus function (HXC-D70K only)

The lens is equipped with two independent focus wheel mechanisms which can be switched between Auto Focus mode and Full Manual Focus mode by sliding the focus ring back and forth.

## Auto Lens Aberration Compensation (ALAC) function

The ALAC function automatically reduces chromatic aberration of magnification when a lens supporting ALAC function is attached.



## Three assignable buttons

Favorite functions can be assigned for quick shooting. The HXC-D70 is easily customized for often-used operations.

- Gain
- Output
- White Balance
- Menu/Status

## Front audio input

Microphone or Line audio signals can be input. The HXC-D70 also has an audio input connector on the rear panel, which allows stereo recording.

# HXCU-D70 Camera Control Unit

The HXCU-D70 is equipped on its front panel with often-used switches and controls for easy camera operation. It can also be remotely controlled without using a remote control panel (RCP). The HXCU-D70 provides rich camera control functions.

- Cable alarm indicator
- Camera power indicator
- Intercom I/O & control block (PROD/ENG lines)
- Two assignable buttons
- Panel lock switch
- Menu control block
- Assignable knob
- Picture control block

### Wide viewable range in action

Wide range of right-side vision through this area enables the camera operator to move around with confidence while shooting.



### Sony's standard shoe fits a battery and other accessories

Stand-alone operation is achieved without a camera control unit - simply attach a battery and various other accessories.

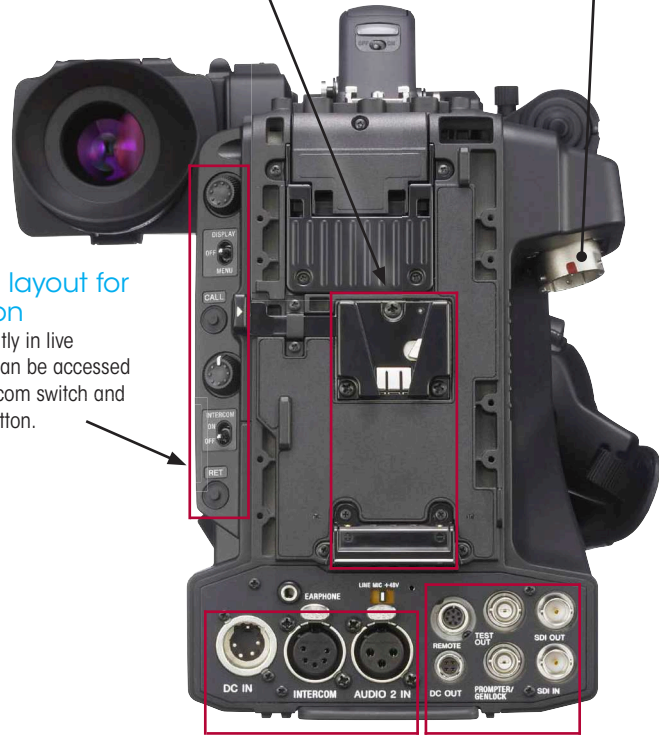

### Direct-mounted HD/SD multi-core connector

### Simple interface layout for intuitive operation

The buttons used frequently in live production applications can be accessed easily, including the Intercom switch and return video operation button.

### Adjustable shoulder pad

The position of the shoulder pad can be adjusted - either forwards or backwards - to provide the operator with a comfortable, well-balanced camera, when docked with a camera adaptor.

- Intercom I/O
- Audio input
- DC input
- Earphone
- Line/Mic/+48 V selectable

- Remote
- DC output
- Test output
- Prompter output or Genlock input
- SDI output
- HD-SDI input

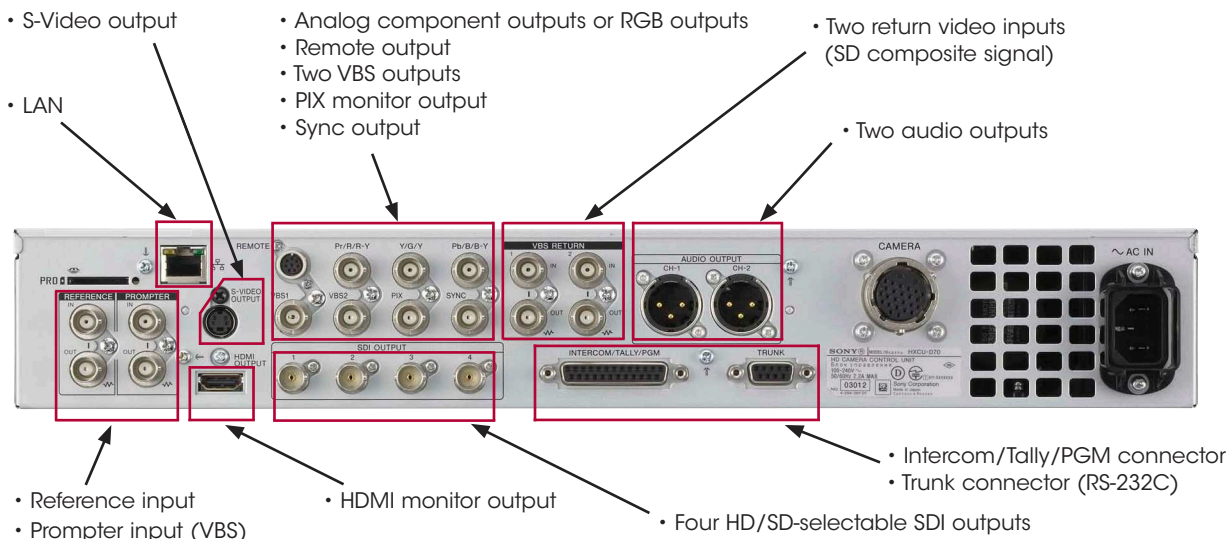

- S-Video output
- LAN
- Reference input
- Prompter input (VBS)
- Analog component outputs or RGB outputs
- Remote output
- Two VBS outputs
- PIX monitor output
- Sync output
- Two return video inputs (SD composite signal)
- Two audio outputs
- Intercom/Tally/PGM connector
- Trunk connector (RS-232C)
- Four HD/SD-selectable SDI outputs

# Interface of HXC-D70 and HXCU-D70

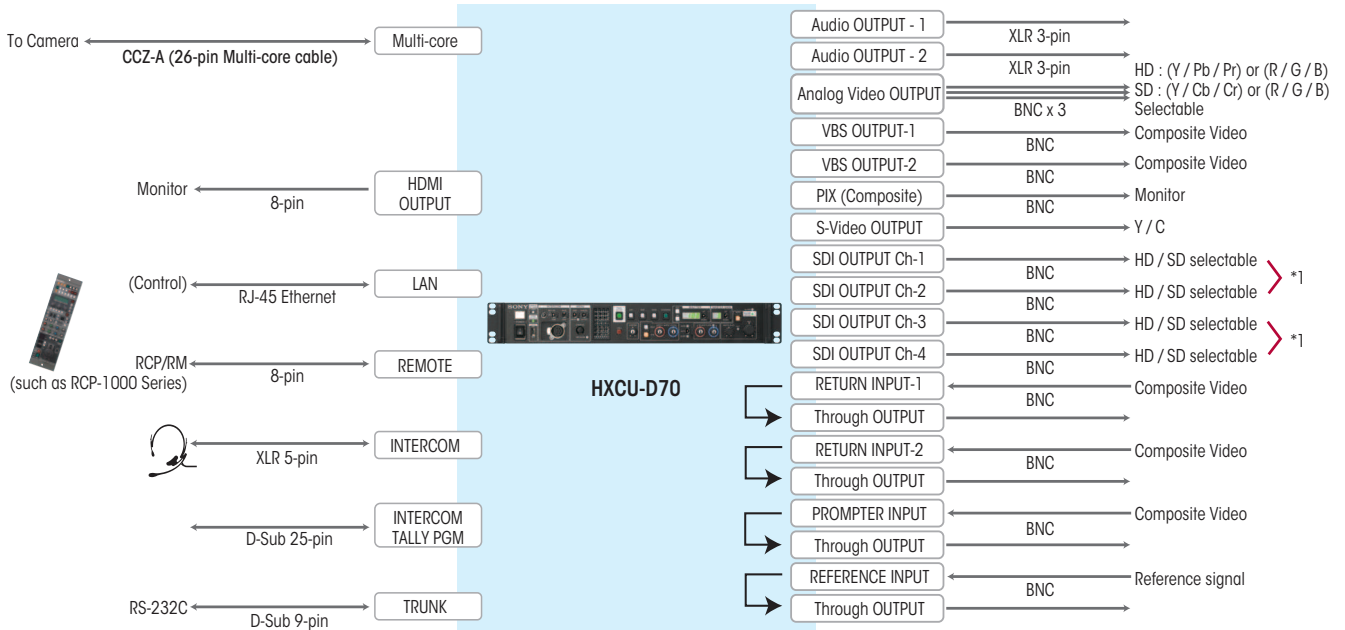
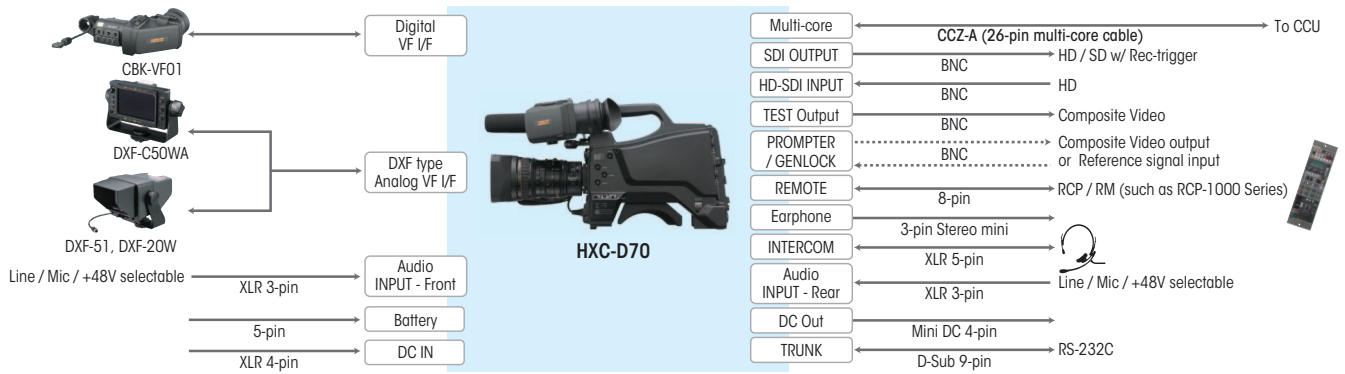

\*1 SDI OUTPUT Ch-1 to Ch-4 connectors output signals in HD-SDI or SD-SDI signal format. The format is set together in a pair as channel 1&2 and 3&4. SDI OUTPUT Ch-3 and Ch-4 connectors can also output signals with a superimposed character or marker display.

## DXF-C50WA 5-inch LCD Color Viewfinder

- 5-inch color IPS-LCD Viewfinder with wide viewing angle
- Image Magnification and Peaking Plus functions to assist focusing
- Ideal viewfinder for the HXC-D70 in HD/SD live shooting applications



# Variety of supplied accessories package

## HXC-D70H



- Camera Main Unit

## HXC-D70L



- Camera Main Unit
- Supplied Viewfinder
- Microphone

## HXC-D70K



- Camera Main Unit
- Supplied Viewfinder
- Microphone
- Auto Focus Lens

Lens Specifications (Supplied lens for HXC-D70K)	
Lens mount	2/3-type Sony bayonet
Zoom ratio	1.6x (optical), servo/manual
Focal length	f = 8 mm to 128 mm (the equivalent of 31.5 mm to 503 mm on a 35 mm lens)
Iris	F1.9 to F16 and Close, auto/manual selectable
Focus	AF/MF/Full MF selectable, 800 mm to ∞ (MACRO OFF), 50 mm to ∞ (MACRO ON, Wide), 732 mm to ∞ (MACRO ON, Tele)
Image stabilizer	ON/OFF selectable, shift lens
Filter diameter	M82 mm, pitch 0.75 mm (on lens)

# Optional Accessories



**CBK-VF01**  
3.5-inch\*1 LCD Color Viewfinder



**DXF-20W**  
2.0-inch\*1 CRT B&W Viewfinder



**DXF-51**  
5.0-inch\*1 CRT B&W Viewfinder



**RCP-1000**  
Remote Control Panel



**RCP-1001**  
Remote Control Panel



**RCP-1500**  
Remote Control Panel



**RCP-1501**  
Remote Control Panel



**RCP-1530**  
Remote Control Panel

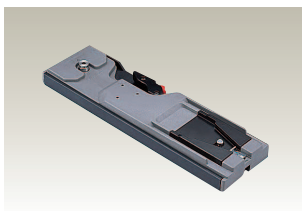

**VCT-U14**  
Tripod Adaptor



**CCZ-A5/A10/A25/A50/A100**  
Connecting Cable (26-pin - 26-pin)



**WRR-861A/861B**  
UHF Synthesized Tuner



**DWR-S01D**  
Digital Wireless Receiver\*2

\*1 Viewable area measured diagonally

\*2 The DWA-01D Digital Wireless Adaptor is required. Some functions of the DWR-S01D are limited when the CCU-D50 Camera Control Unit is connected.

# Dimensions

Unit: mm (inches)

## HXC-D70

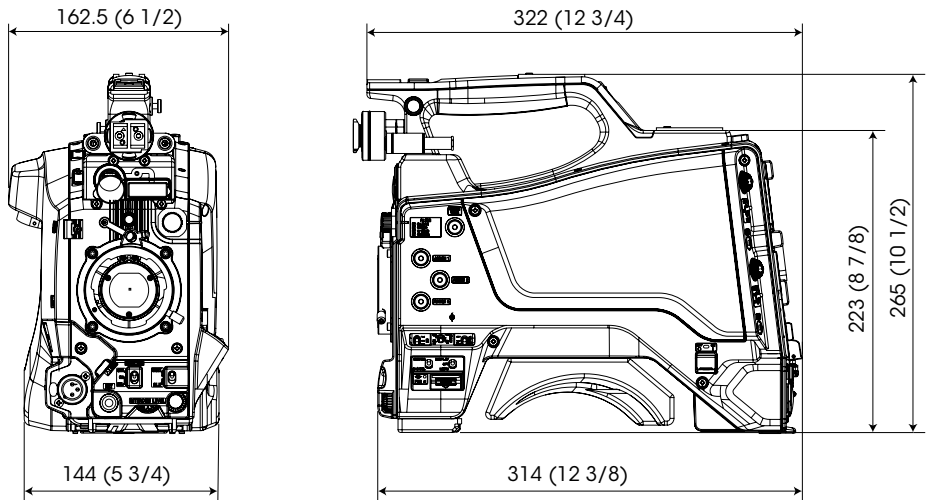

## HXCU-D70

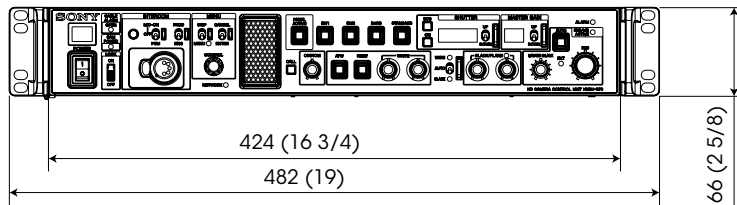

# Specifications

HXC-D70	
<b>General</b>	
Power requirement	12 V AC (10.5 V to 17 V)
Operating temperature	-10°C to +45°C (14°F to +113°F)
Storage temperature	-20°C to +60°C (-4°F to +140°F)
Mass	3.4 kg (7 lb 7.9 oz)
<b>Camera section</b>	
Pickup device	3-chip 2/3-inch type Exmor Full-HD CMOS
Effective picture elements (H x V)	1920 x 1080
Signal format	Selectable from 1080i/59.94, 720p/59.94, 1080i/50, 720p/50
Spectrum system	F1.4 prism system
Built-in filters	1: CLEAR, 2: 1/4ND, 3: 1/16ND, 4: 1/64ND
Sensitivity	F12 (typical) (1920 x 1080/59.94i mode), F13 (typical) (1920 x 1080/50i mode) (at 2000 lx, 3200 K, 89.9% reflectance)
Signal-to-noise ratio (typical)	Approx. 59 dB (Y) (typical)
Horizontal resolution	1,000 TV lines or more (in 1920 x 1080i mode) 920 TV lines (in SD mode)
<b>Input/Output</b>	
Audio input	XLR 3-pin (x2, at front panel and rear panel)
Prompter output/Genlock input	BNC (x1), 1 Vp-p, 75 Ω
DC input	XLR 4-pin (x1)
DC output	4-pin (x1)
Test output	BNC (x1)
HD-SDI input	BNC (x1)
SDI output	BNC (x1)
Earphone output	Mini-jack 3-pin (x1)
CCU	CCZ 26-pin (x1)
Trunk	D-sub 9-pin, female (x1), RS-232C interface
Intercom	XLR 5-pin, female (x1)
Remote	8-pin (x1)
Viewfinder	Digital interface (x1) and DXF type analog interface (x1)
<b>Supplied accessories</b>	
Viewfinder (HXC-D70K/D70L only) (1), Monaural microphone (HXC-D70K/D70L only) (1), Windscreen (1) (HXC-D70K/D70L only), Lens mount cap, Flange back adjustment chart (HXC-D70K only), Auto focus lens (HXC-D70K only) (1), Operating Instructions (1), CD-ROM (1)	

HXCU-D70	
<b>General</b>	
Power supply	100 V AC to 240 V AC, 50/60 Hz
Operating temperature	5°C to 40°C (41°F to 104°F)
Storage temperature	-20°C to +60°C (-4°F to +140°F)
Dimensions (W x H x D)	482 x 66 x 360 (19 x 2 5/8 x 14 1/4 in, 1.5U rack-mount size)
Mass	6.5 kg (14 lb 5.2 oz)
<b>Input/Output</b>	
Camera	CCZ 26-pin (x1)
Intercom/Tally/PGM	D-sub 25-pin (x1) female • Intercom (PROD and ENG), 4W/RTS/CC, 0 dBu • TALLY (R, G) • PGM (x1) system, -20/0/+4 dBu
Remote	8-pin (x1)
Trunk	D-sub 9-pin (x1) female, RS-232C system
LAN	RJ-45 8-pin (x1) Control
SDI output	BNC (x4) HD/SD-selectable at each pair of two outputs
Analog video output	BNC (x3) Selectable from HD (Y/Pb/Pr or R/G/B) or SD (Y/Cb/Cr or R/G/B)
S-Video (Y/C) output	Mini DIN 4-pin (x1)
VBS output	BNC (x2)
HDMI monitor output	Type A 19-pin (x1), HDMI version: Ver. 1.3
PIX (monitor, VBS) output	BNC (x1)
Audio output	XLR 3-pin (x2)
Return input (VBS)	BNC (x2) with loop-through output BNC (x2)
Prompter input (VBS)	BNC (x1) with loop-through output BNC (x1)
Reference input	BNC (x1) with loop-through output BNC (x1) HD: SMPTE 274M, tri-level sync, 0.6 Vp-p, 75 Ω SD: Black burst (NTSC: 0.286 Vp-p, 75 Ω; PAL: 0.3 Vp-p, 75 Ω)
Intercom headset	XLR 5-pin (x1)
<b>Supplied accessories</b>	
Number plates (1 set), Operating Instructions (1), CD-ROM (1)	

## Distributed by

MK10839V3KURA11JUL

© 2011 Sony Corporation. All rights reserved.  
Reproduction in whole or in part without written permission is prohibited.  
Features and specifications are subject to change without notice.  
"SONY", "make.believe", and "Exmor" are trademarks of Sony Corporation.  
All other trademarks are the property of their respective owners.

The HXC-D70 and HXCU-D70 are produced at Sony EMCS Corporation's Tokai Technology Center, which has received ISO14001, the Environmental Management System certification.

